

DURAN® FILTERING APPARATUS

The DURAN® filtering apparatus is made of high-quality borosilicate glass. Apart from the glass, the medium only comes into chemical contact with PTFE. That is why the apparatus can be used to filter virtually any chemical.

The PTFE disc holder allows both glass filters of different porosities and slit-sieve discs to be used. Thanks to the range of porosities available with glass filters (10 µm – 160 µm), analytical filtration can be carried out in addition to coarse and fine filtration.

The DURAN® filtering apparatus is suitable for filtration and purification of aqueous and organic solutions as well as for particulate contamination analysis and preparation of HPLC media.

Product benefits:

- Only glass and PTFE come in contact with the medium
- Removable filter discs ensure easy cleaning
- Slit-sieve disc included to hold filter papers and membrane filters (diameter 47 mm)
- Graduated filter head
- Reliable plastic hose connection (suitable for tubes with ID 8 mm)
- All components available as replacement parts



DURAN® PTFE ADAPTER

The DURAN® PTFE Adapter complements the DURAN® filtering apparatus, making it possible to filter directly into a DURAN® pressure plus+ laboratory bottle. The adapter connects the 45/40 standard ground joint of the DURAN® filtering apparatus to the GL 45 thread of a DURAN® laboratory bottle.

Product benefits:

- Direct filtration into a DURAN® pressure plus+ laboratory bottle
- The filtrate can be stored or used immediately without additional transfer – for example with a GL 45 HPLC screw cap or other GL 45 connection system
- Reduced risk of contamination



Note:

As a vacuum is created in the bottle during filtration, use of the DURAN® pressure plus+ laboratory bottle is recommended.

Order information:

Order No.	Description	pieces per pack
DURAN® Filtering apparatus, complete		
25 710 54 51	DURAN® Filtering apparatus, 1000 ml/250 ml	1
25 710 63 04	DURAN® Filtering apparatus, 2000 ml/500 ml	1
Replacement Parts		
29 400 28 03	PTFE adapter plate	1
29 076 36 09	Clamp (anodized aluminum)	1
24 722 36 02	Graduated filter head 250 ml	1
24 722 44 01	Graduated filter head 500 ml	1
24 317 32 03	Extension NS 45/40	1
24 202 54 04	DURAN® filter flask with NS 45/40, 1000 ml	1
24 202 63 06	DURAN® filter flask with NS 45/40, 2000 ml	1
29 255 06 03	Plastic hose connection with silicone seal, straight GL 14	10
29 227 05 08	Threaded cap, red, made of PBT, GL 14, hole 9.5 mm	10
25 205 02 08	DURAN® glass filter disc, diameter 50 mm, por. 2	1
21 340 31 08	Slit-sieve disc, diameter 48 mm	1

Pos.	Description
1	DURAN® filter flask with standard ground joint 45/40
2	Extension, standard ground joint 45/40, with hose connection GL 14
3	PTFE adapter plate
4a	DURAN® glass filter disc, diameter 50 mm
4b	DURAN® slit-sieve disc, diameter 48 mm
5	Graduated filter head
6	Clamp (anodized aluminum)
7	Plastic hose connection with silicone seal, straight
8	Threaded cap, red, made of PBT, GL 14

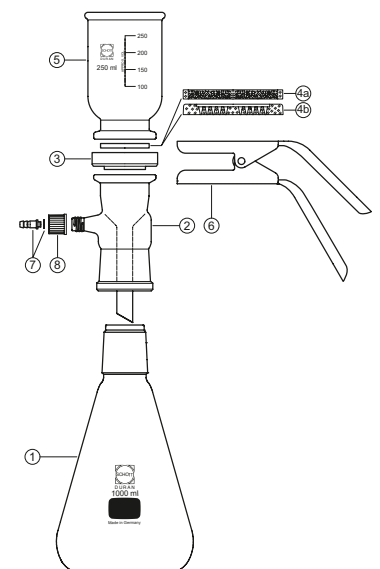

Order No.	Description	Standard ground joint	Thread	pieces per pack
29 400 12 07	DURAN® PTFE adapter NS 45/40 – GL 45	45/40	GL 45	1

PTFE: Polytetrafluorethylene

These products are available from your laboratory supplier: